



ioSafe 1517 Hardware Guide

Powered by Synology DSM

Table of Contents

Chapter 1: Before You Start

Package Contents	3
ioSafe at a Glance.....	4
Safety Instructions.....	5

Chapter 2: Hardware Setup

Tools and Parts for Hard Disk Installation	6
Install Hard Disks	6
Connecting Your ioSafe	10
Replace System Fan Assembly	11

Chapter 3: Install Synology DiskStation Manager

Install DSM with Web Assistant.....	12
-------------------------------------	----

Chapter 4: Product Support

Data Recovery Procedure	13
Contact Us	13







Appendix A: Specifications

Appendix B: LED Indication Table

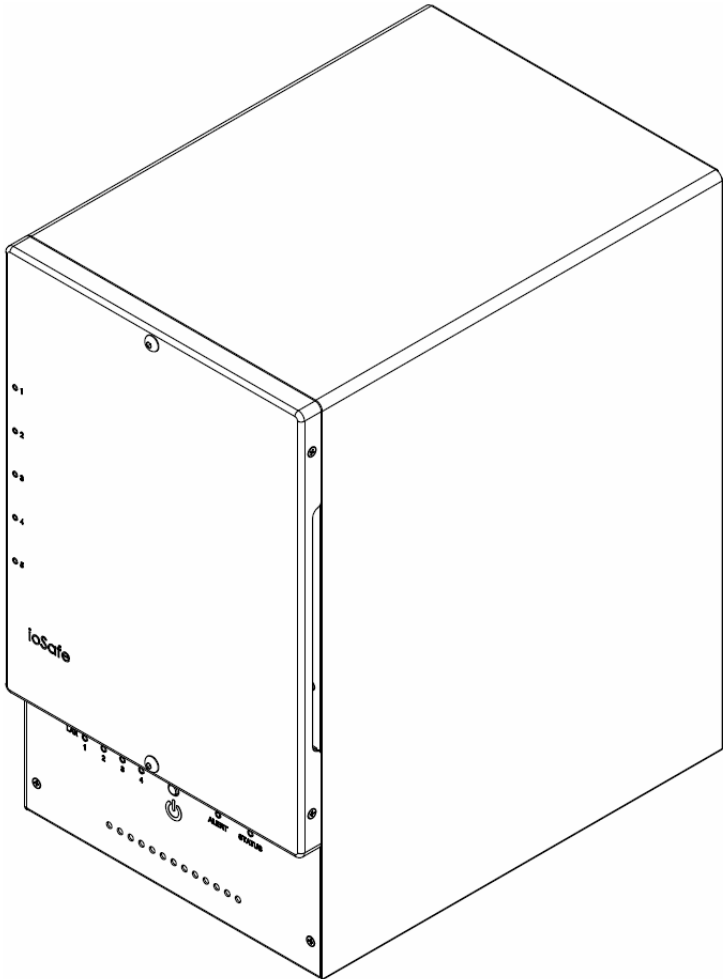
Before You Start

Before you start setting up the ioSafe, please check the package contents to verify that you have received the items below. Please also read the safety instructions carefully before use to prevent your ioSafe from any damages.

Package Contents

Main unit x 1 	AC power cord x 1  RJ-45 LAN cable x 1  Screws for 3.5" hard drives x 24  3mm Hex Tool x1  Magnet x1  Note: For storing the Hex Tool on the back of the device
--	--



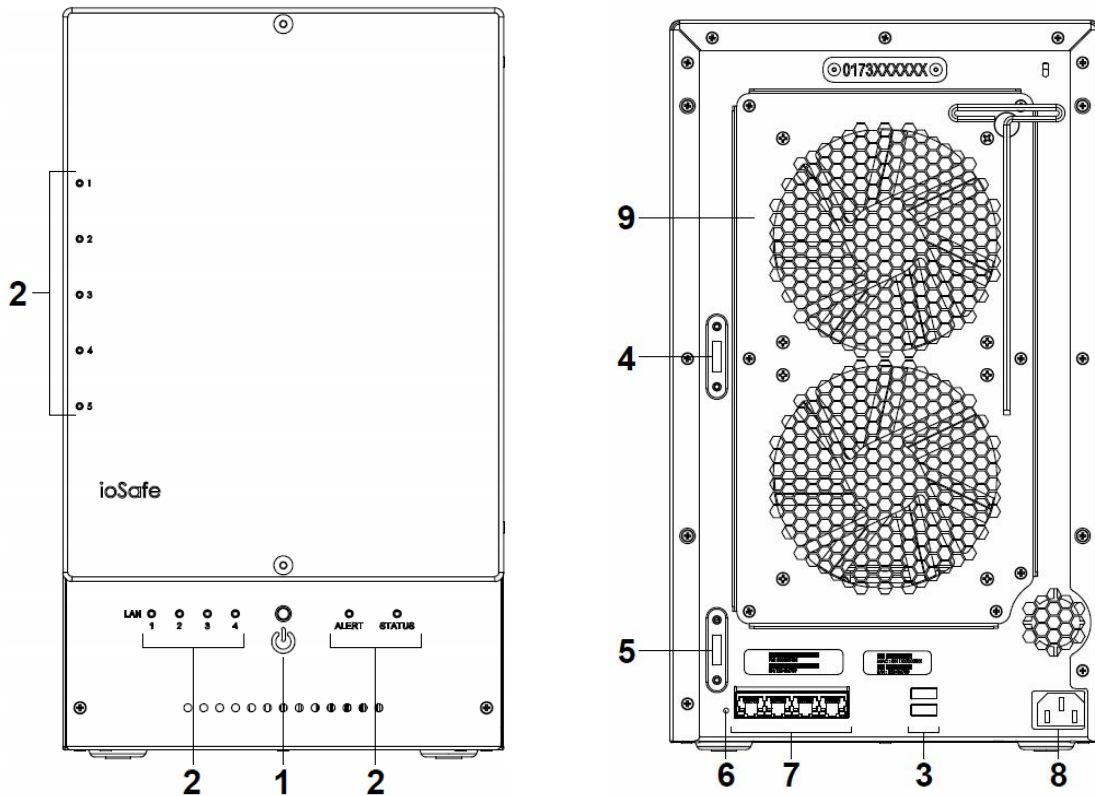

ioSafe at a Glance



No.	Article Name	Location	Description
1)	Power Button	Front Panel	The power button is used to turn your ioSafe on or off. To turn off your ioSafe, press the Power Button and hold it until you hear a beep sound and the Power LED starts blinking.
2)	LED Indicators	Front Panel	The LED indicator is used to display the status of the internal disk and the system. For more information, see "Appendix A: LED Indication Table" on Page 15.
3)	USB 3.0 Ports	Back Panel	The ioSafe offers USB ports for adding additional external hard drives, USB printers, or other USB devices.
4)	eSATA 1	Back Panel	The eSATA ports are used to connect external SATA disks or Expansion Units ¹ to the ioSafe.
5)	eSATA 2		
6)	RESET Button	Back Panel	1. To restore IP, DNS, passwords for the admin account to default value. 2. To reinstall the ioSafe.
7)	LAN Ports	Back Panel	The LAN ports are where you connect RJ-45 cable to the ioSafe.
8)	Power Port	Back Panel	The power port is where you connect the power cord to the ioSafe.
9)	Fans	Back Panel	The fans are built to exhaust waste heat. It will start automatically when the server starts. If the fan is malfunctioning, the system will beep every few seconds.

Safety Instructions

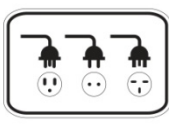
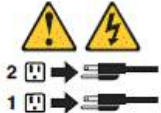
¹ For more information about ioSafe Expansion Unit supported by your DiskStation, please visit www.iosafe.com.

	<p>Before cleaning, unplug the power cord first. Wipe ioSafe product with damp paper towels.</p>
	<p>Do not place the ioSafe product on a cart, table, or desk, which is not stable to avoid the product from falling over.</p>
	<p>The power cord must plug in to the right supply voltage. Make sure that the supplied AC voltage is correct and stable.</p>
	<p>To remove all electrical current from the device, ensure that all power cords are disconnected from the power source.</p>
	<p>Risk of explosion if battery is replaced with an incorrect type. Dispose of used batteries appropriately.</p>
<p>3-2-1</p>	<p>At ioSafe, we suggest a minimum of the "3-2-1 Rule" for backup: Make 3 complete copies of your data, keep them on at least 2 separate systems, and have at least 1 protected from natural disaster.</p>

Hardware Setup

Tools and Parts for Hard Disk Installation

- A Phillips screwdriver
- 3mm Hex Tool (included)
- At least one 3.5" or 2.5" SATA hard disk
(Please visit www.iosafe.com for compatible hard disk models.)

Warning: If you install a hard disk that contains data, the system will format the hard disk and erase all data. If you need the data in the future, please back it up before installation.

Install Hard Disks

- 1 Remove the Front Cover using the include 3mm Hex Tool

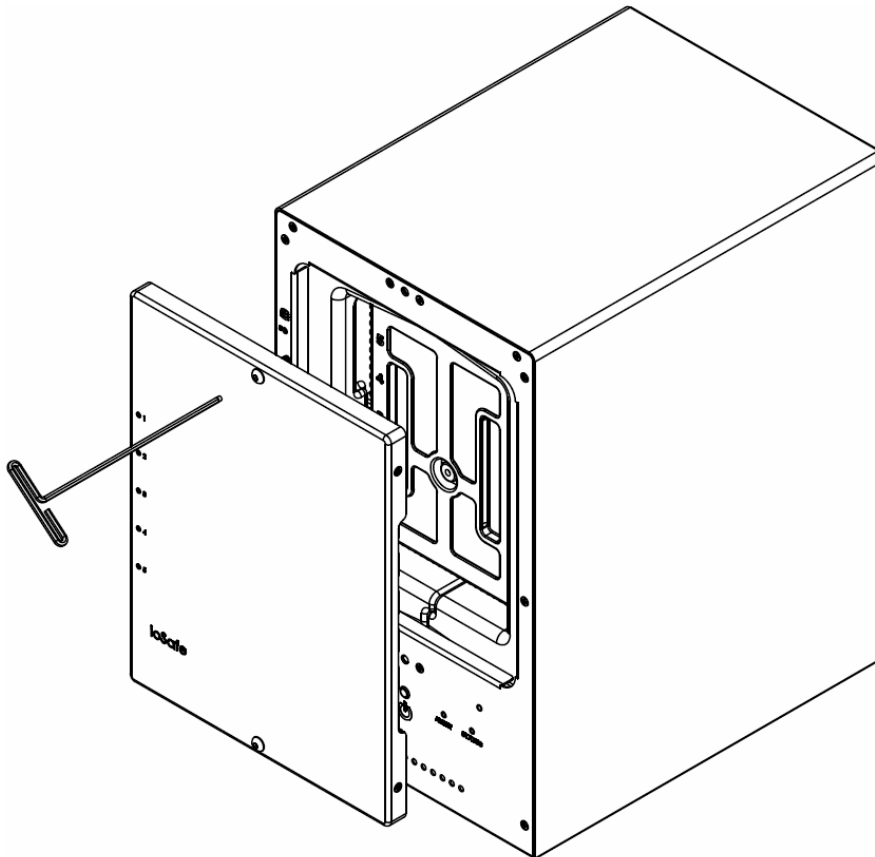

2 Remove the Waterproof Drive Cover using the 3mm Hex Tool.

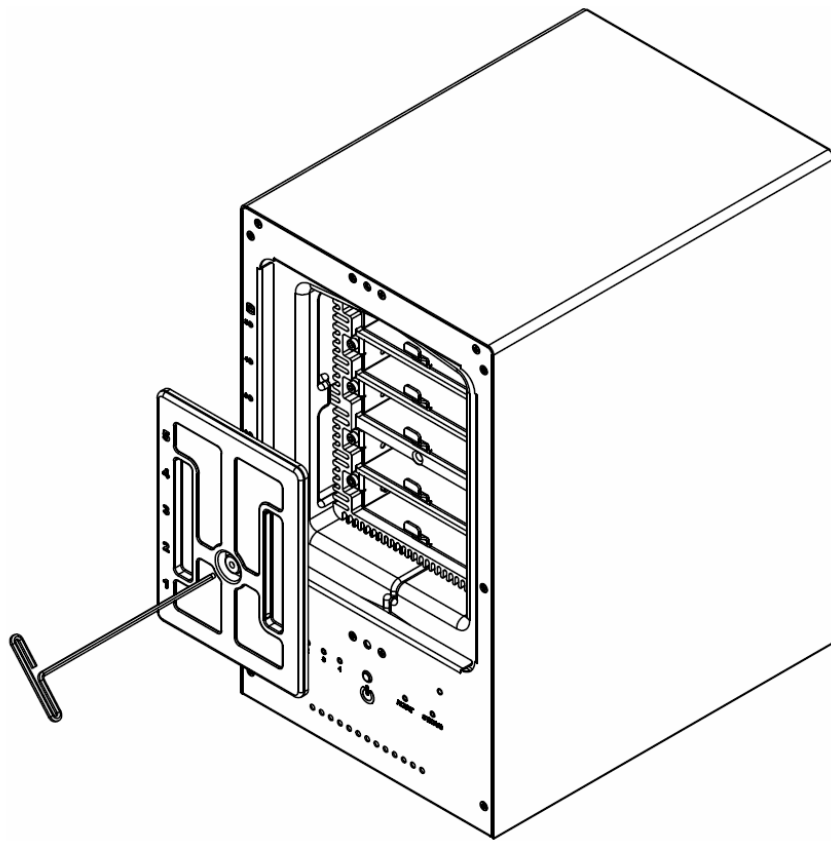

3 Remove the Drive trays using the provided 3mm Hex Tool.

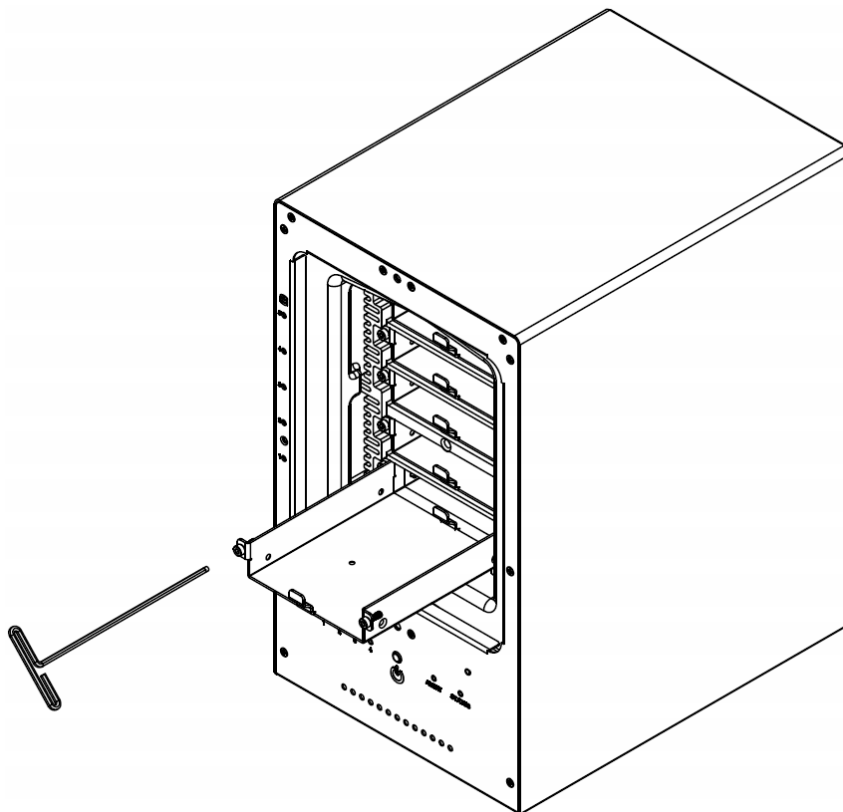

- 4 Install a compatible Hard Drive into each Drive Tray using (4x) Drive Screws and a Phillips screwdriver.
(Please visit www.iosafe.com for compatible hard drives models.)

Note: If you want to set up a RAID set, it is recommended that all installed hard disks are of the same size to make the best use of hard disk capacity.

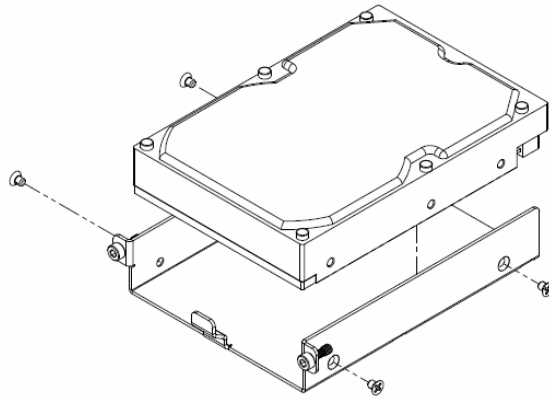

- 5 Insert the loaded hard drive tray into the empty hard drive bay and tighten the screws using the 3mm Hex Tool.

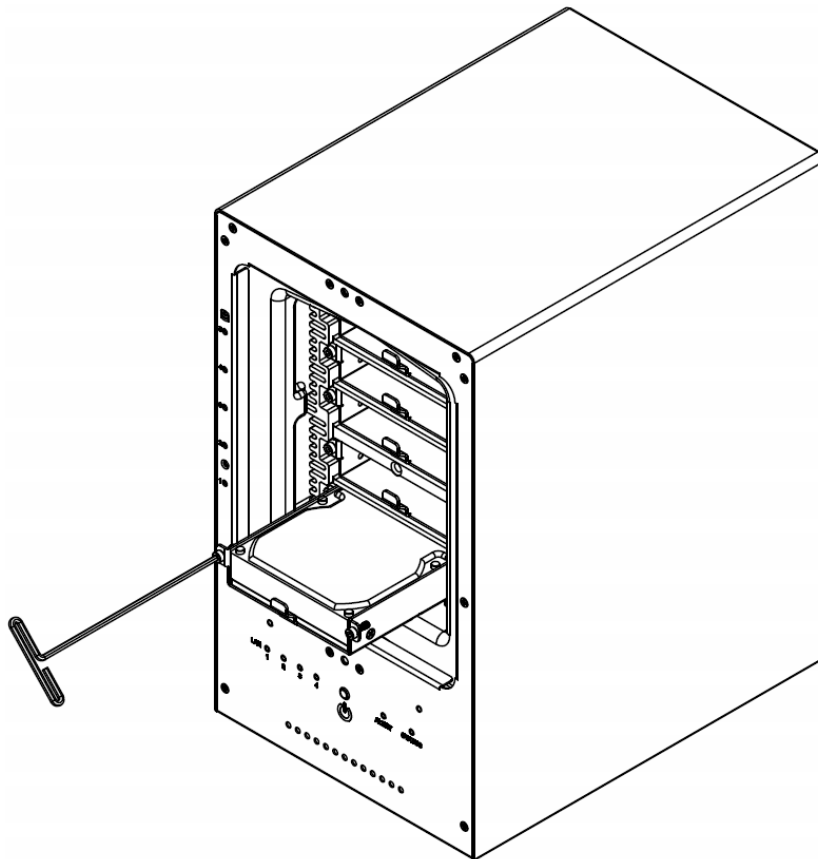

Important: Make sure the tray is pushed in all the way. Otherwise, the hard disk might not be able to function properly.

- 6 Replace the Waterproof Drive Cover and securely tighten using the supplied 3mm Hex Tool

WARNING: BE SURE TO TIGHTEN THIS SCREW USING THE PROVIDED HEX TOOL. THE HEX TOOL IS DESIGNED TO FLEX SLIGHTLY WHEN THE SCREW IS SUFFICIENTLY TIGHT AND THE WATERPROOF GASKET IS PROPERLY COMPRESSED. AVOID USING TOOLS OTHER THAN THE SUPPLIED HEX TOOL AS YOU COULD UNDER TIGHTEN OR BREAK THE SCREW.

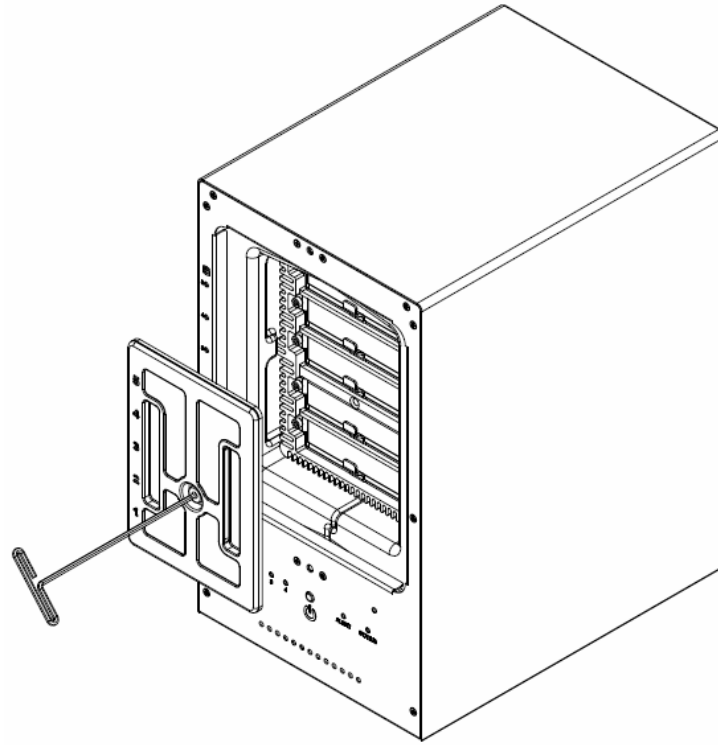

- 7 Install the Front Cover to finish the installation and protect the drives from fire. Keep the Hex Tool nearby for future use. A magnet is provided to attach the Hex Tool to the back of the ioSafe or some other convenient location.

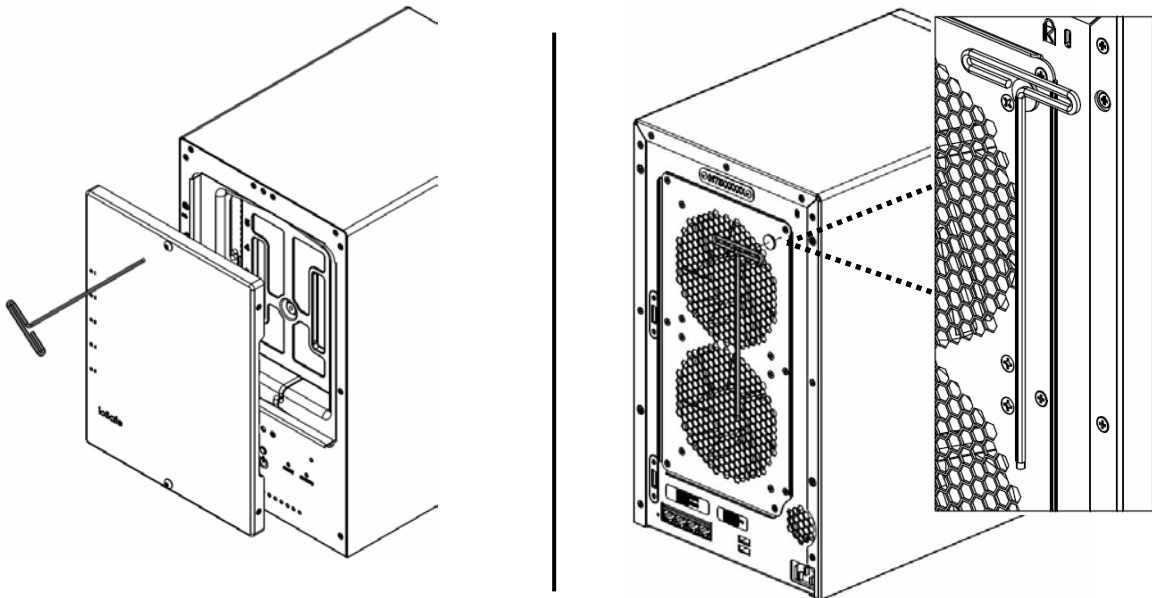

Connecting Your ioSafe

- 1 Use the LAN cable to connect the ioSafe to your switch/router/hub.
- 2 Connect one end of the power cord to the power port of your ioSafe, and the other to the power outlet.
- 3 Press and hold the power button to turn on your ioSafe.

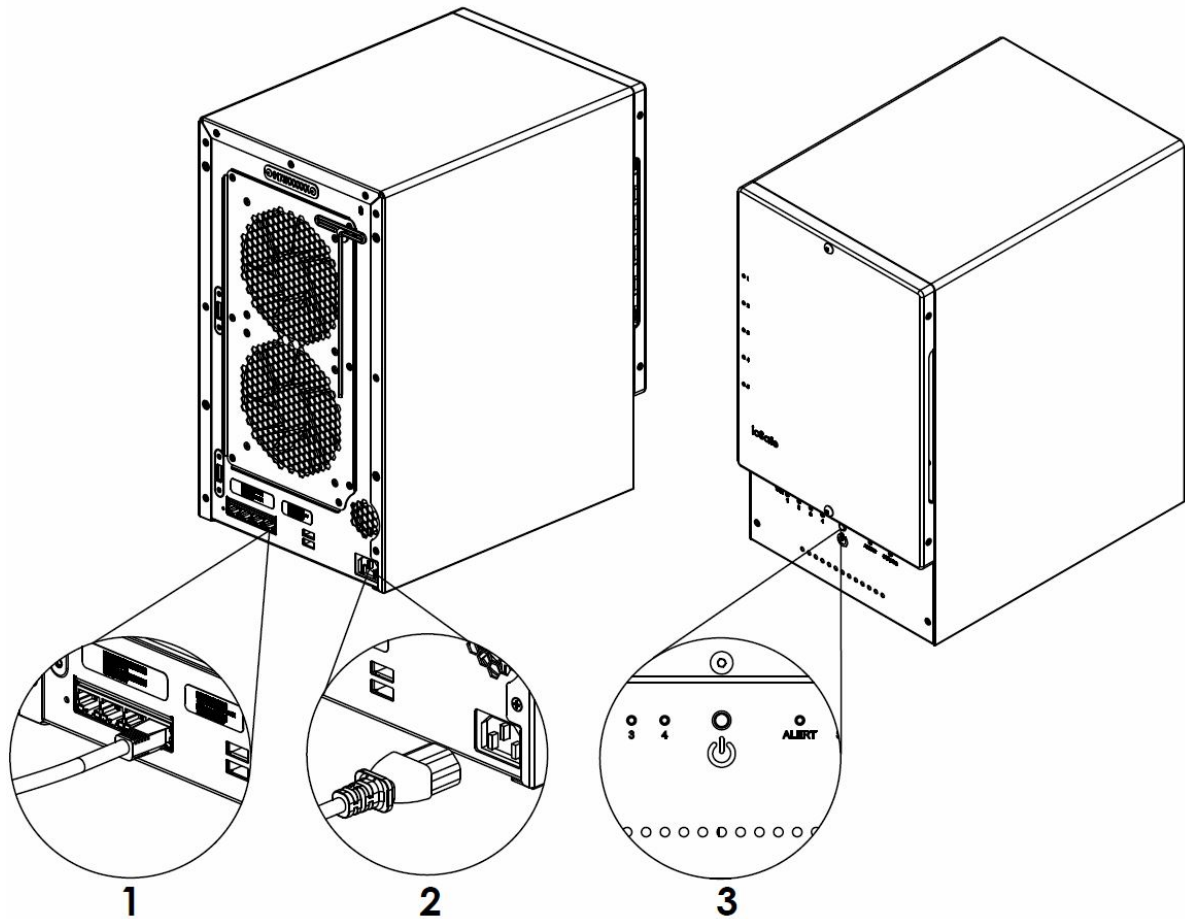

Your ioSafe is now online and detectable from a network computer.

Replace System Fan Assembly

Your ioSafe will play beep sounds if either of the system fans is not working. Follow the steps below to replace the malfunctioning fans with a good set.

To replace the system fans:

- 1 Shut down your ioSafe. Disconnect all cables connected to your ioSafe to prevent any possible damages.
- 2 Remove the 7 perimeter screws that secure the malfunctioning fan assembly.
- 3 Remove the malfunctioning fan assembly:
 - a Pull the assembly from the back panel of your ioSafe to expose the fan connections.
 - b Disconnect the fan cables from the connector located near the bottom of the fan socket, and then remove the assembly.

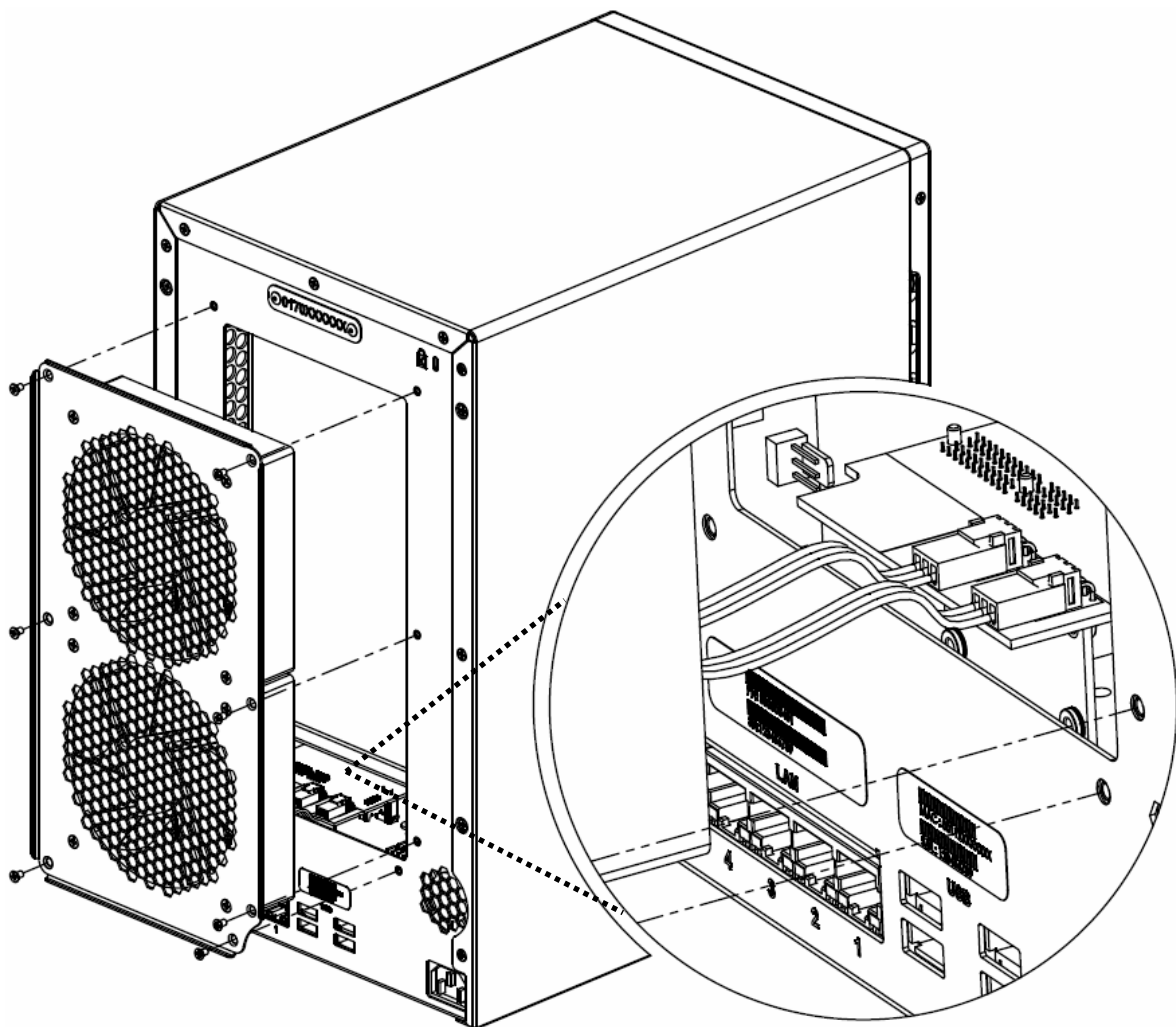

- 4 Install the new fan assembly:
 - a Connect the fan cables of the new fans to the fan connectors.
- 5 Replace and tighten the 7 screws you removed in step 2.

Install Synology DiskStation Manager

Synology DiskStation Manager (DSM) is a browser-based operating system which provides tools to access and manage your ioSafe. When installation is complete, you will be able to log into DSM and start enjoying all the features of your ioSafe powered by Synology. To get started, please see the steps below.

Install DSM with Web Assistant

Your ioSafe comes equipped with Web Assistant, a browser-based installation tool which helps you download, configure, and install the newest version of DiskStation Manager (DSM). Before installing DSM with Web Assistant, please check the following:

- Your computer and your ioSafe must be connected to the same local network.
- In order to download the latest version of DSM, Internet access must be available during installation.

After confirming, please follow the steps below:

1 Power on your ioSafe.

1 Open a web browser on your computer and go to find.synology.com.

Note: Web Assistant is optimized for Chrome and Firefox web browsers.

2 Web Assistant will find your ioSafe within the local network. The status of your ioSafe should be **Not Installed**.



3 Click **Connect** to begin the setup process. Follow the onscreen instructions to complete the setup process.

Note: ioSafe uses an unmodified version of Synology's DSM. The software interface will sometimes refer to the Synology Product the ioSafe is based on; Synology DS1517

4 A web browser should open showing the Login screen. Enter the 'admin' as the username and leave the password field blank as shown below.

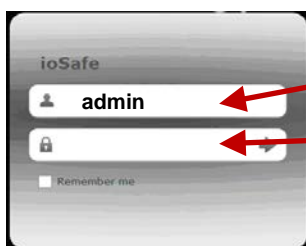

Default user name: admin

Leave this field empty

Product Support

Congratulations! You are now ready to manage and enjoy all the features of your ioSafe. For more information regarding specific features, please check out **DSM Help** or refer to our online resources available at www.iosafe.com or www.synology.com.

Data Recovery Procedure

If the ioSafe faces possible data loss for any reason, you should immediately call the ioSafe Disaster Response Team at 1-888-984-6723 (US & Canada) or 1-530-820-3090 (International) extension 430. You can also send an email to disastersupport@iosafe.com. The professionals at ioSafe can determine the best actions to take to protect your valuable information. In some cases a self-recovery can be performed and provide you with immediate access to your information. In other cases, ioSafe may request that the product be returned to the ioSafe factory for data recovery. In any case, contacting ioSafe is the first step.

The general steps for disaster recovery are:

1. Email disastersupport@iosafe.com with your serial number, product type and date of purchase.
2. If you cannot email, call ioSafe Disaster Support Team at 1-888-984-6723 (US & Canada) or 1-530-820-3090 (International) extension 430
3. Report disaster event, and obtain return shipping address/instructions
4. Follow ioSafe team instructions on proper packaging.
5. ioSafe will recover all data which is recoverable according to the terms of the Data Recovery Service Terms and Conditions.
6. ioSafe will then place any recovered data on a replacement ioSafe device
7. ioSafe will ship the replacement ioSafe device back to the original user
8. Once the primary server / computer is repaired or replaced, the original user should restore the primary drive data with the ioSafe backup data

Contact Us

Customer Support

USA Toll Free Phone: 888.98.IOSAFE (984.6723) x400

International Phone: 530.820.3090 x400

Email: customersupport@iosafe.com

Technical Support

USA Toll Free Phone: 888.98.IOSAFE (984.6723) x450

International Phone: 530.820.3090 x450

Email: techsupport@iosafe.com

Disaster Support

US Toll Free Phone: 888.98.IOSAFE (984.6723) x430

International Phone: 530.820.3090 x430

Email: disastersupport@iosafe.com

Corporate Headquarters

ioSafe, Inc.

10600 Industrial Ave, Suite 120

Roseville CA 95678

Specifications

Item	ioSafe NAS 1517
Fire Protection	Protects data from fire. Up to 1550°F (843°C), 30 minutes per ASTM E-119.
Flood Protection	Protects data from flood. Fully submersed, fresh or salt water, 10 foot (3m) depth, 72 hours.
Internal HDD	3.5" or 2.5" SATA (II) x 5
Max. Capacity	60TB (5x 12TB hard drives) 180TB (15x 12TB hard drives) with two DX517 (expansion units)
Hot Swappable HDD	Yes
External Device Ports	USB 3.0 x 2 eSATA x 2
LAN Port	Gigabit x 4
USBCopy	No
Size (HxWxD) (mm)	375 x 222 x 318
Weight (Kg)	27 (59 lbs)
Supported Clients	Windows XP onward Mac OS X 10.5 onward Ubuntu 9.04 onward
File System	• Internal: EXT4 • External disk only: EXT4, EXT3, FAT, NTFS, HFS+, exFAT
Volume Type	• Basic • JBOD • RAID 0 • RAID 1 • RAID 5 • RAID 6 • RAID 10 • Synology Hybrid RAID (Up to 2-Disk Fault Tolerance)
HDD Hibernation	Yes
Scheduled Power On/Off	Yes
Wake on LAN	Yes
Language Localization	• English • Deutsch • Français • Italiano • Español • Dansk • Norsk • Svensk • Nederlands • Русский • Polski • Magyar • Português do Brasil • Português Europeu • Türkçe • Český • 日本語 • 한국어 • 繁體中文 • 简体中文
Power Consumption And Environment Requirements	Line voltage: 100V to 240V AC Frequency: 50/60Hz Operating Temperature: 40 to 95°F (5 to 35°C) Storage Temperature: 15 to 140°F (-10 to 60°C) Relative Humidity: 5% to 95% RH Maximum Operating Altitude: 6500 feet (2000m)

LED Indication Table

LED Indication	Color	Status	Description
STATUS	Green	Static	Volume Normal
		Off	HDD Hibernation
	Orange	Static	Available volume space < 1GB
			Available volume space < 1 %
		Blinking	Volume degraded or crashed
	Green/orange	Alternating	DSM not installed
			No internal disk
Front LAN	Green	Static	Gigabit connection
		Blinking	Network is active
		Off	Network is down
Rear LAN (on upper side of jack)	Green	Static	Gigabit connection
	Orange	Static	100 Mb connection
		Off	10 Mb connection
Rear LAN (on lower side of jack)	Green	Static	Network is connected
		Blinking	Network is active
		Off	Network is down
Hard Drive Status Indicator (on tray)	Green	Static	Disk ready
		Blinking	Disk is being accessed
		Off	No internal disk
	Orange	Static	Cannot Read/Write
ALERT	Orange	Blinking	FAN failure or over temperature
		Off	System normal
Power	Blue	Static	Power ready
		Blinking	Booting up
			Shutting down
		Off	Power off